



# CRANE ATTACHMENTS

## RAILROAD TIE GRAPPLER

## 20 SERIES



PROUDLY MADE  
IN THE U.S.A.

## FEATURES 20 SERIES

- Straight tine ends engineered for removing rail ties from railroad cars
- 1 ½" thick tines for extra heavy duty service
- Jaws are replaceable and exchangeable
- All components are Hi Tensile Steel
- Straight tine design used by many Class I railroads
- CN certified for use on their rail lines
- 11 ton HD continuous rotation standard
- 3 ½" bore 3,000 psi load holding cylinders

920.682.6111

HEIDENCRANE.COM





# 20 SERIES RAILROAD RAILROAD TIE GRAPPLES

HC20-AHR-3 / HC20-AHR-4

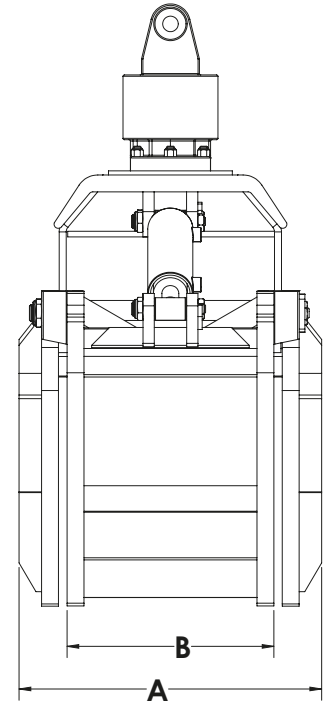
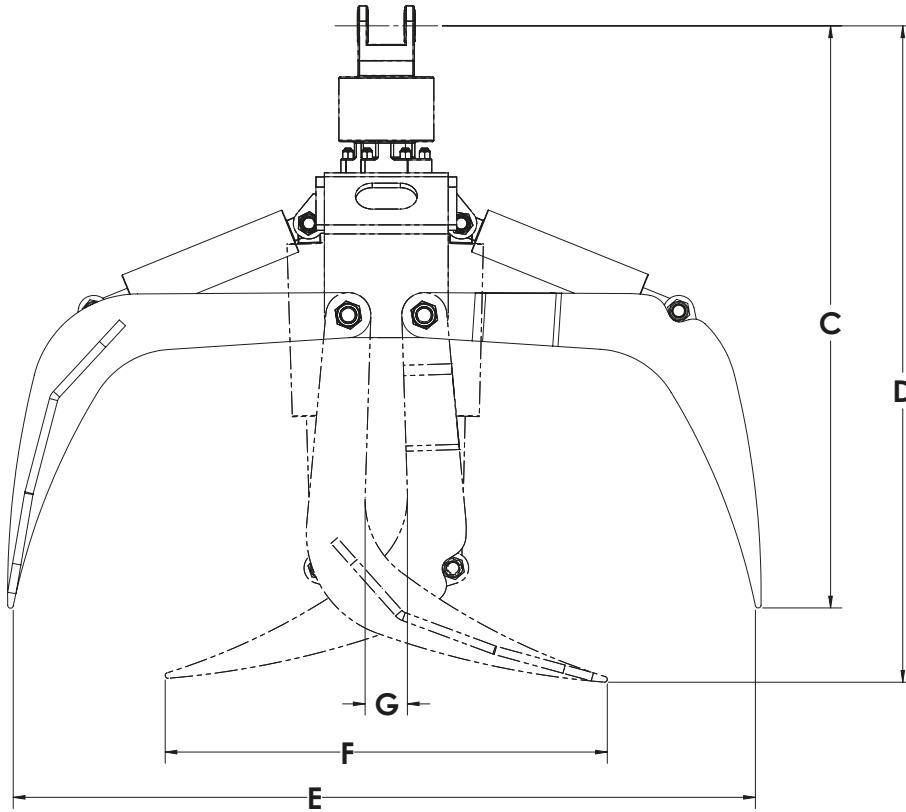

Specifications	HC20-AHR-3	HC20-AHR-4
A	27"	27"
B	18 3/8"	18 3/8"
C	52"	52"
D	63"	58"
E	74"	66"
F	39"	37"
G	7"	7"
Weight (With Rotator)	1,100 lb	1,000 lb

\*Heiden Inc., reserves the right to change these specifications without notice and without incurring any obligation relating to such changes.

OUR RELIABILITY, DELIVERY, AND INTERCHANGEABLE CUSTOM DESIGNS WILL IMPROVE YOUR BOTTOM LINE.



Interchangeable Components



Exceptional Durability



Fast Turnaround



Made in USA

4624 Expo Dr. Manitowoc, WI 54220  
Toll Free: 888.682.5779 Phone: 920.682.6111  
Fax: 920.682.3174  
Email: heiden@heidenco.com

[HEIDENCRANE.COM](http://HEIDENCRANE.COM)



HEIDEN, INC IS AN ISO 9001-2015 CERTIFIED COMPANY



PROUDLY MADE IN THE U.S.A.