



Powerful Synergies



# COPMA

218

**ESSENTIAL  
MODEL**

# COPMA 218

Performance & Power

**218 IS INNOVATIVE ENGINEERING  
FOR TOP PRECISION, EFFICIENCY,  
SPEED AND PERFORMANCE.  
AN ESSENTIAL MASTERPIECE  
OF LIFTING TECHNOLOGY.**

- **ESSENTIAL model, load category - 21 Ton/Mt**
- **Essential in design, powerful in performance**
- **Robust arm system**
- **Simple and reliable**
- **Excellent operational safety**





**THE MOST  
POWERFUL  
CRANE FOR  
THE TOUGHEST  
MARKETS**



# COPMA 218

More Safety & Security

**DESIGNED WITH THE HIGHEST  
HYDRAULIC SYSTEMS AND THE  
TOUGHEST STRUCTURAL STEEL  
TO PERFORM THE MAXIMUM  
LIFTING CAPACITY.**

- **Optimized and reliable hydraulic technology**
- **Column with high mechanical characteristics**
- **High Degree of User Friendliness**
- **Efficiency and Reliability thanks to essential design**
- **Excellent weight/performance ratio**





**DESIGNED  
FOR FLEXIBLE  
SERVICES**



# COPMA 218

## Technical Features

**CUTTING EDGE FEATURES  
FOR MAXIMUM LIFTING  
POWER, STABILITY AND  
OPERATIONAL SAFETY IN EVERY  
WORKING CONDITION.**

### Standard features

- control
  - \* **TAD**  
control
  - \* **CMS 1.0**  
control
  - \* **TES 2.0**  
control
- structure
  - CCLS**  
structure
  - NBS**  
structure
  - RRP**  
structure

### optional features

- easy use
  - HLS 2.0**  
easy use
  - MLS 2.0**  
easy use
  - ERD**  
easy use
  - HSE**  
easy use
- control
  - WLC**  
control
  - RRC 3.0**  
control
  - \* **CMS 2.0**  
control

\*E.C. market specific equipment





### Crane Monitoring System 1.0

Crane stability control system TES1-TES2, safety control and overload control for medium-small cranes. Controlling the crane in 4 work areas, each area can have custom lifting settings depending on the vehicle stability.



### Radio Remote Control 3.0

Radio control with directly flanged actuation electronics with proportional distribution. The remote control allows operating the crane while constantly monitoring the areas of operation.



### Constant Control Link

The cranes equipped with connecting rods on the articulations, with a constant lifting moment over the entire working arc, allow to 100% optimize the crane's capacity in positions close to the maximum vertical.

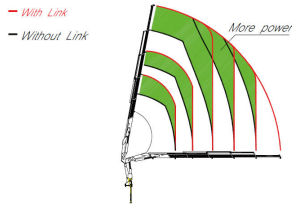

### Transport Alert Device

Sensors on the basement control the correct closing of the beams and a column switch sensor indicates if the crane is in a folded position, no more than 4 mt in height. The operator is warned with light and sound signals in the truck cabin.



### Rotation Rack Pinion

The rotation system with rack and pinion is the best optimal solution for the most performative lifting capacity, it reduce the weights and crane dimension for the most compact configuration.



### Truck Electronic Stability 2.0

Active stability control for performance optimization according to the type of stabilization (2) to guarantee maximum safety in all working conditions. Mandatory in the CE market, it helps a better vehicle-crane configuration.

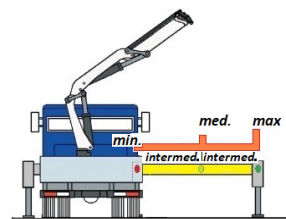

### Electronic Radio Display

A display on the remote control allows the operator to maintain the total control of all the crane functions in real time by managing the work mode, the stability control, and oversee any maintenance and diagnostic messages.

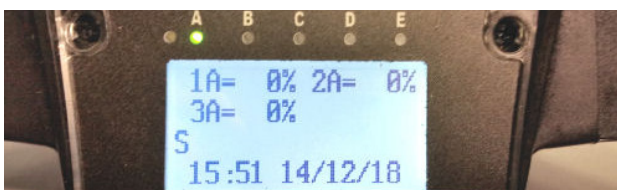

### Negative Boom System

The linkage on the articulation of the secondary boom permits the introduction of loads within restricted spaces. It enables the recovery of the deflection of the extension boom group due to the weight and the load raised on the extensions.

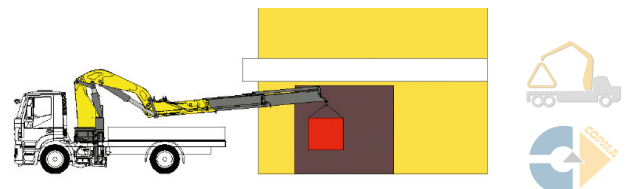



### Hydraulic Lifting Stabilizers 2.0

The cylinder of the stabilizer is lifted with an auxiliary jack, allowing the vertical movement within the bushes or rotating around a pin. It saves operative time in increasing the security of the setup.

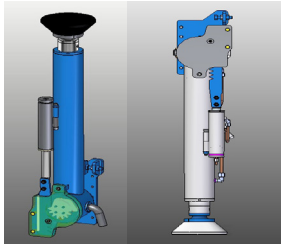

### Manual Lifting Stabilizers 2.0

Manual raising of the stabilizers facilitated by a compressed gas cylinder which assists the operator during the rotation of the jack. This system assists the operator with less effort in adjusting the legs.

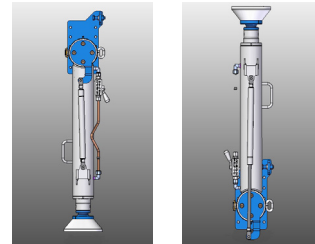

### Winch Linear Control

The winch linear electronic control allows pulling the rope according to the working angle of the crane and the JIB. It optimizes the load control and makes every movement easier and safer.

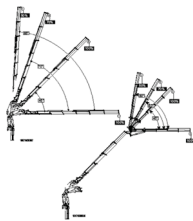

### High Speed Extension

Hydraulic system for reducing load losses and bottlenecks for the correct output sequence of the extensions by increasing the speed of 30%-60% thanks to the regenerative valve. Greater continuous performance thanks to lower fluid temperature.



### Crane Monitoring System 2.0

Crane stability control system TES2-TES3 with safety and overload controls and HPVE lifting speed management. Active control on 4-8 working areas according to the model and vehicle stability requirements.





# 218 ESSENTIAL

## Load Charts

### 2 extensions

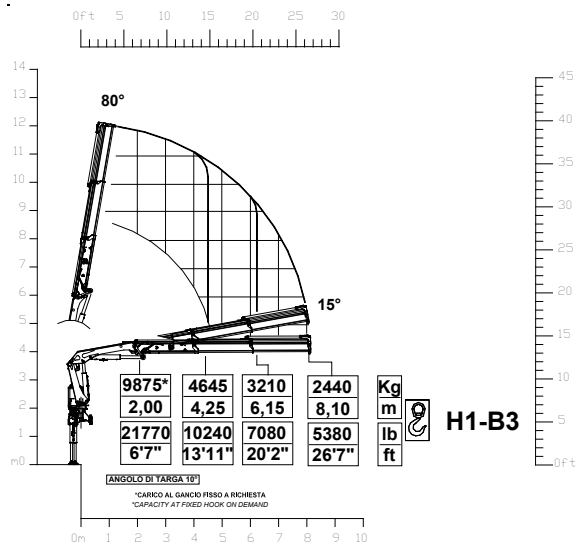

### 3 extensions

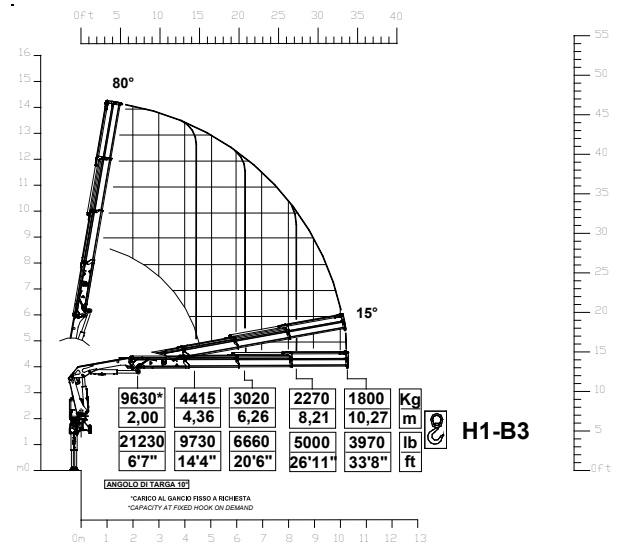

### 4 extensions

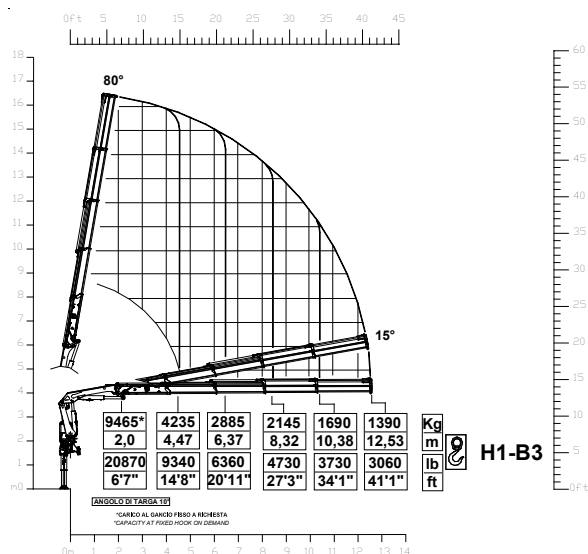

### 5 extensions

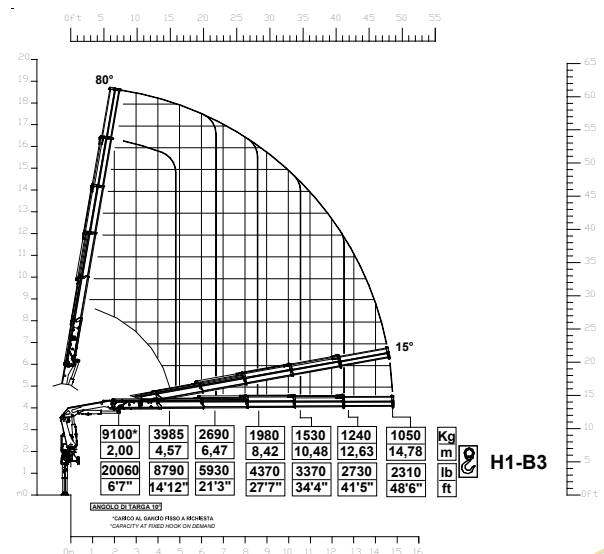

## 6 extensions

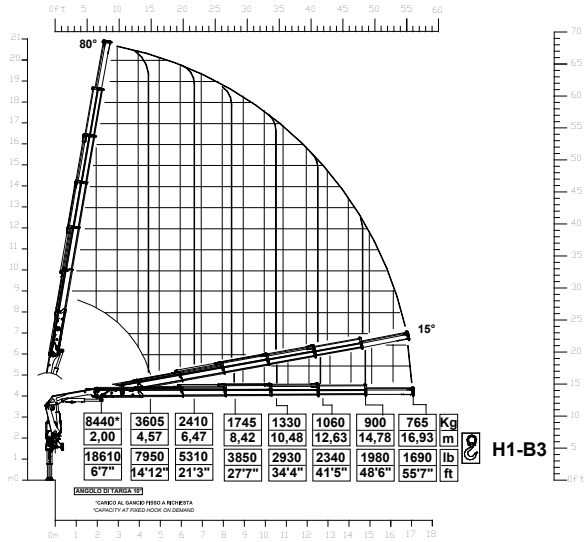

# 218 ESSENTIAL

## Crane Dimensions

back cabin left

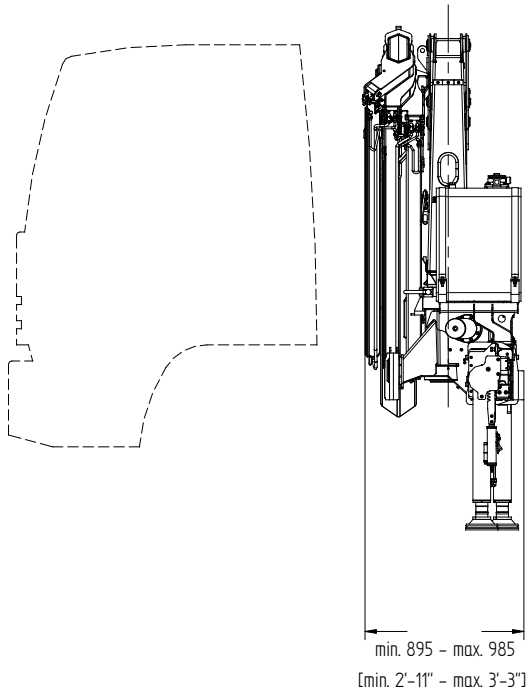

rear truck

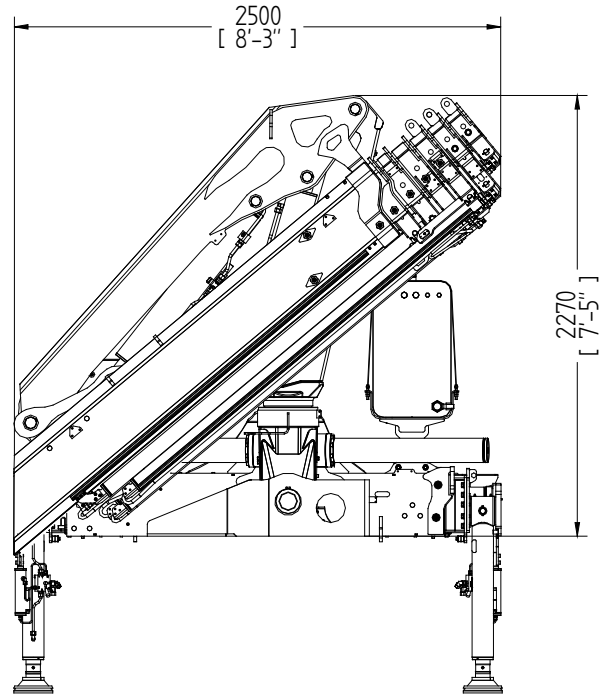

top cabin

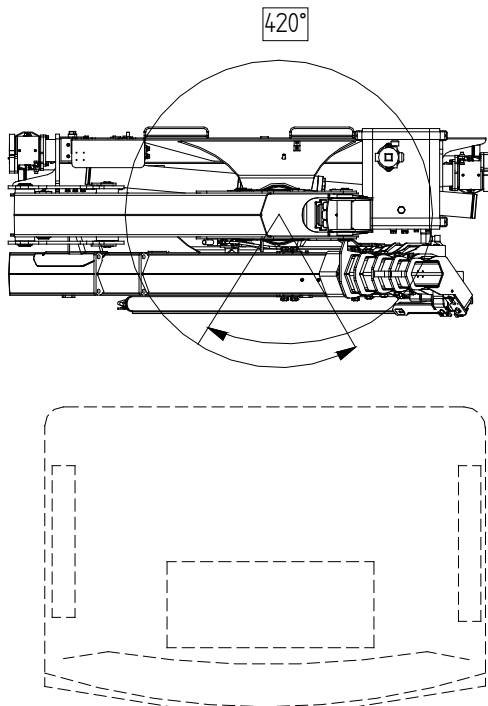

operational

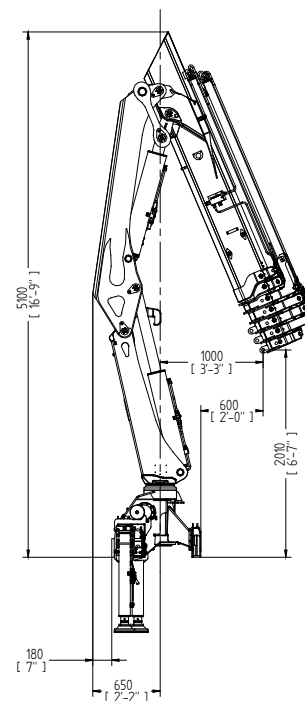

operational

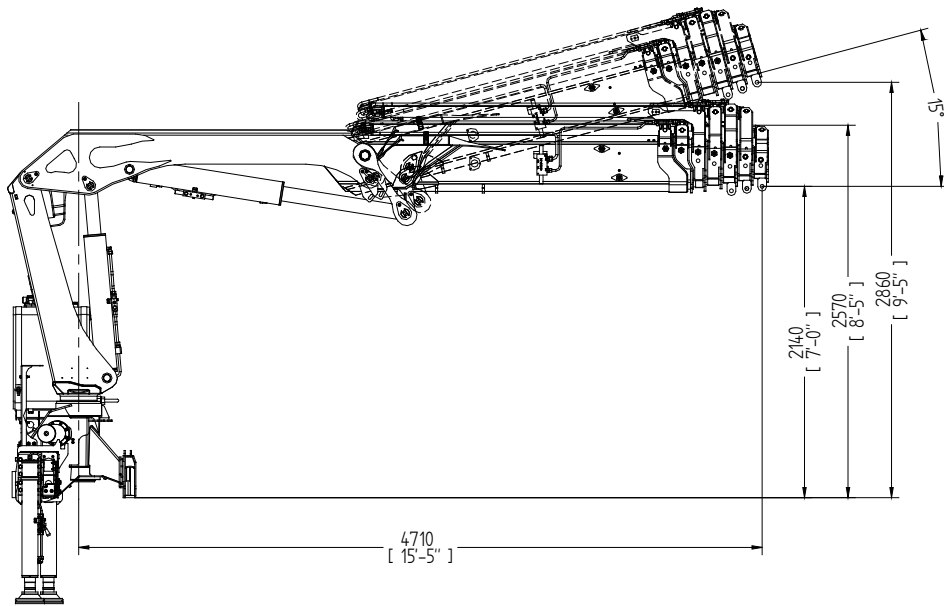

extended outriggers

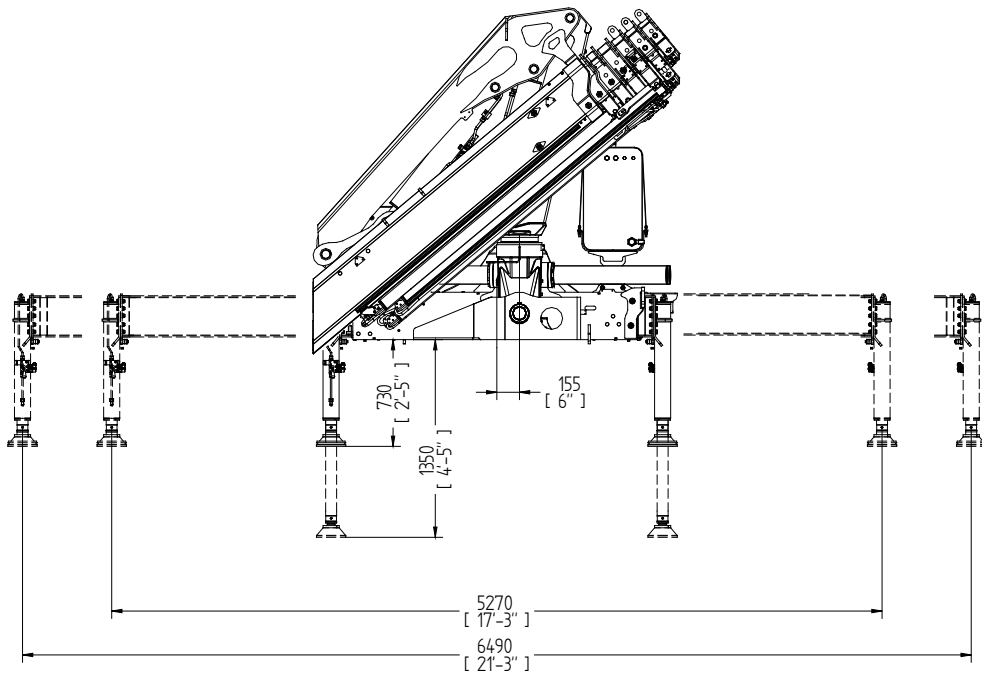









\* Note:  
 Technical features are not binding.  
 The company reserves itself the right to any modification without notice











# 218 ESSENTIAL

## Technical Data

### summarized data

									
	kN.m	bar	l/min	kg	°	mm	mm	mm	mm
218.2	193.9	320	50	2160	420	2500	895	2270	5270/6500
218.3	188.9	320	50	2290	420	2500	895	2270	5270/6500
218.4	185.6	320	50	2420	420	2500	925	2270	5270/6500
218.5	178.6	320	50	2540	420	2500	985	2270	5270/6500
218.6	165.6	320	50	2640	420	2500	985	2270	5270/6500

									
	lbs.ft	psi	gal/min	lbs	°	ft/inc	ft/inc	ft/inc	ft/inc
218.2	142964	4641	13,21	4761	420	8'2"	2'11"	7'5"	17'3"-21'3"
218.3	139277	4641	13,21	5048	420	8'2"	2'11"	7'5"	17'3"-21'3"
218.4	136844	4641	13,21	5335	420	8'2"	3'	7'5"	17'3"-21'3"
218.5	131683	4641	13,21	5599	420	8'2"	3'3"	7'5"	17'3"-21'3"
218.6	122140	4641	13,21	5820	420	8'2"	3'3"	7'5"	17'3"-21'3"

### technical data

<b>Max. lifting moment</b>	193 kNm	142964 ft.lbs
<b>Max. hydraulic outreach</b>	17.03 m	56'04"
<b>Slewing angle</b>	420°	420°
<b>Slewing torque</b>	2840 daNm	20939 ft.lbs
<b>Stabilizer spread</b>	5.27/6.5 mt	17'3"/21'3"
<b>Fitting space required (min./max)</b>	0.89 m/0.98 m	2'10"/3'2"
<b>Width folded</b>	2,50 m	8'2"
<b>Max. operating pressure</b>	320 bar	4641 psi
<b>Recommended pump capacity</b>	50 l/min	13.21 US gal./min
<b>Dead weight (vers .2)</b>	2160 kg	4761 lbs

\* Note:  
 Technical features are not binding.  
 The company reserves itself the right to any modification without notice







**GET READY TO A  
BETTER LIFTING  
EXPERIENCE**



# COPMA 218



knuckle  
boom  
cranes



Powerful Synergies



**CPS**



**CPS  
STEEL**

## CPS GROUP S.P.A.

281 Via Emilia , Castel Bolognese (RA) , 48018  
Italy

T +39 0546 653 711

[sales.cpsgroup@cps-group.com](mailto:sales.cpsgroup@cps-group.com)

[service.cpsgroup@cps-group.com](mailto:service.cpsgroup@cps-group.com)

[cps-group.com](http://cps-group.com)

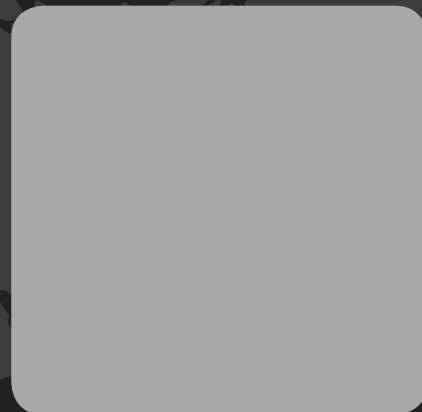

COPMA MODEL 218 ESSENTIAL 5-2019 all rights reserved CPS GROUP S.P.A.

